The Automotive EN-2000™ Router

Hardware Description and Installation

The chassis for the automotive EN-2000™ router connects to a standard 12-volt or 24-volt automotive battery, and can be used in cars, buses, trucks, and heavy equipment. This special router provides all the features of the standard EN-2000™ router.

The automotive EN-2000 is based on the hardened version of the EN-2000, with RS232 and RS485 ports for supervisory control and data acquisition (SCADA).

There are several uses for the automotive EN-2000. Some examples are:

- Connection of SCADA systems for refrigeration in cold-food-distribution trucks
- WiFi connection for cellphones and tablets, to secure back-end databases for emergency-service vehicles and personnel, such as police, fire, and ambulance
- Digital video recording (DVR), to provide quick reference to recent streaming video (for example, incident review) or to provide information on the recording system itself (for example, the amount of remaining storage), in buses and coaches
- WiFi and internet access to management systems for drivers of trucks and heavy-duty vehicles
- WiFi for passengers in buses and coaches

See the following:

- [Section C.1, Automotive EN-2000 Router Hardware Description](#), on page 2
- [Section C.2, Installing the Automotive EN-2000 Router in a Vehicle](#), on page 3
- [Section C.3, Connecting the Automotive EN-2000 Chassis to Automotive Power](#), on page 3

Note: The automotive EN-2000 is configured as the standard EN-2000 is configured. See the [EN-2000™ Reference Manual](#) for a list of documents discussing configuration.

In addition, see the document [Setting the Ignition Power-Off Delay for the Automotive EN-2000™ Router](#).

C.1 Automotive EN-2000 Router Hardware Description

See the following:

- [Section C.1.1, Front Panel of the Automotive EN-2000 Chassis](#), on page 2
- [Section C.1.2, Back Panel of the Automotive EN-2000 Router](#), on page 3

C.1.1 Front Panel of the Automotive EN-2000 Chassis

Figure C-1 shows the faceplate for the automotive EN-2000 without serial ports.

Figure C-1. EN-2000 Front Panel without Serial Ports



The front of the automotive EN-2000 router's chassis without serial ports has:

- One LED for power status (PWR)
- One LED for system status (SYS)
- One LED for data activity (ACT) on the LAN port or WAN port
- LEDs to indicate cellular wireless activity (CELL) and network status (NET)
- Two RJ45 Ethernet ports (LAN and WAN)
- A slot for a SIM
- Two SMA connectors for antennas to support cellular wireless modules
- One reset switch (for default software/configuration load)
- [Figure C-2](#) shows the faceplate for the automotive EN-2000 with two serial ports (an RS232 port and an RS485 port).

Figure C-2. EN-2000 Front Panel with Two Serial Ports



The front of the automotive EN-2000 router's chassis with two serial ports has all the ports that the chassis without serial ports has. The chassis with serial ports also includes the following ports:

- One RS485 serial port
- One RS232 serial port

Note: [Figure C-2](#) shows a slot for a second SIM.

C.1.2 Back Panel of the Automotive EN-2000 Router

The EN-2000 automotive chassis has a special backplate to accommodate connection to an automotive battery. [Figure C-3](#) shows the backplate for the automotive EN-2000.

Figure C-3. Automotive EN-2000 Back Panel



The back of the automotive EN-2000 router has:

- One DC power connector

Note: The voltage range (9–32 volts) is specified above the DC connector. The automotive EN-2000 connects to an automotive battery.

The automotive EN-2000 has built-in protection against transient voltages. If a transient voltage lasts more than 600 milliseconds, the unit shuts down. When the fault is removed, the automotive EN-2000 automatically restarts in approximately 20 seconds.

- Two reverse-polarity SMA connectors for WiFi antennas

Note: LEDs for power, system status, and network activity are on both the front and the back of the router, for the operator's monitoring convenience.

C.2 Installing the Automotive EN-2000 Router in a Vehicle

Consult your Encore Networks, Inc., sales representative to determine whether to use DIN brackets or right-angle brackets to mount the automotive EN-2000 to vehicles in your fleet. Connect the automotive EN-2000's ports for their network functions.

Note: For general discussion, see the [EN-2000™ Quick Installation Guide](#). Installation of the automotive EN-2000 router will vary a bit from the standard installation, particularly in power connection.

C.3 Connecting the Automotive EN-2000 Chassis to Automotive Power

See the following:

- [Section C.3.1, Making a Permanent Connection to the Automotive EN-2000](#), on page 4
- [Section C.3.2, Using a Temporary Connection to the Automotive EN-2000 for Testing and Evaluation](#), on page 6

C.3.1 Making a Permanent Connection to the Automotive EN-2000

The automotive EN-2000 uses a permanent power connection to your automobile's battery.

Note: Encore Networks, Inc., provides the connectors for the automotive EN-2000's RS485 serial port and its DC power input port. The customer will need to build the cables for those connections.

Figure C-4 through Figure C-6 illustrate the connections from an automotive battery to the automotive EN-2000 chassis:

- [Figure C-4](#) (on page 5) illustrates Automotive EN-2000 Power Connection with Immediate Power-Off.
- [Figure C-5](#) (on page 5) illustrates Automotive EN-2000 Power Connection with Delayed Power-Off.
- [Figure C-6](#) (on page 6) illustrates Automotive EN-2000 Power Connection with Power Always On.

The diagrams use the following key:

- IGN** Ignition detect. This should be connected to vehicle ignition or to an external switch.
- If IGN is connected to GND or is left open, the automotive EN-2000 turns off.
- If IGN is connected to main power, the automotive EN-2000 turns on.
- Automotive EN-2000 ground (GND): Connect this lead to the automotive battery's negative lead.
- BAT** Automotive EN-2000 main input power: Connect this lead to the automotive battery's positive lead.

Figure C-4. Automotive EN-2000 Power Connection with Immediate Power-Off

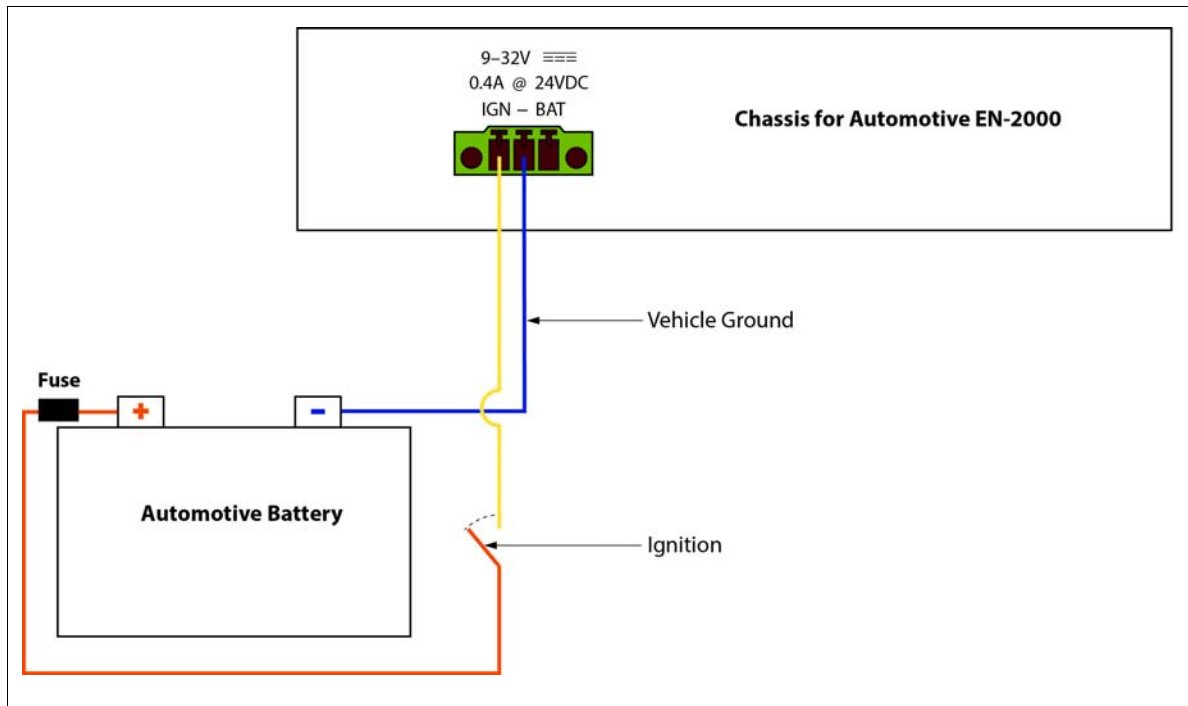

Figure C-5. Automotive EN-2000 Power Connection with Delayed Power-Off

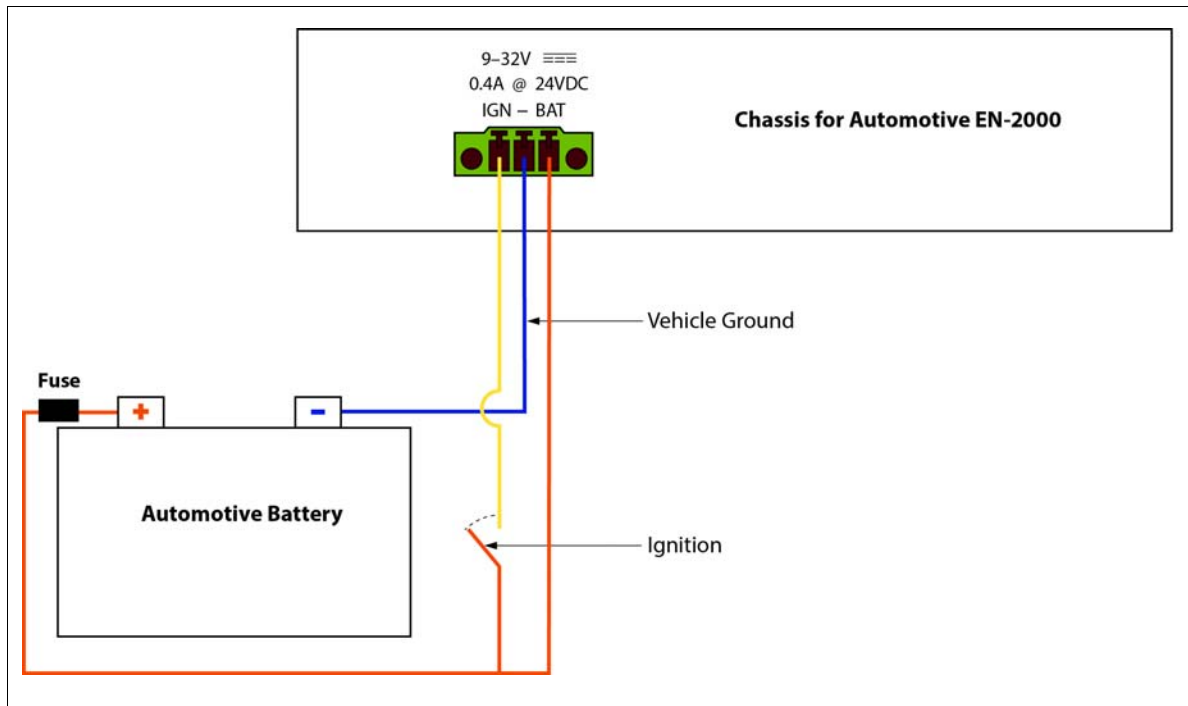
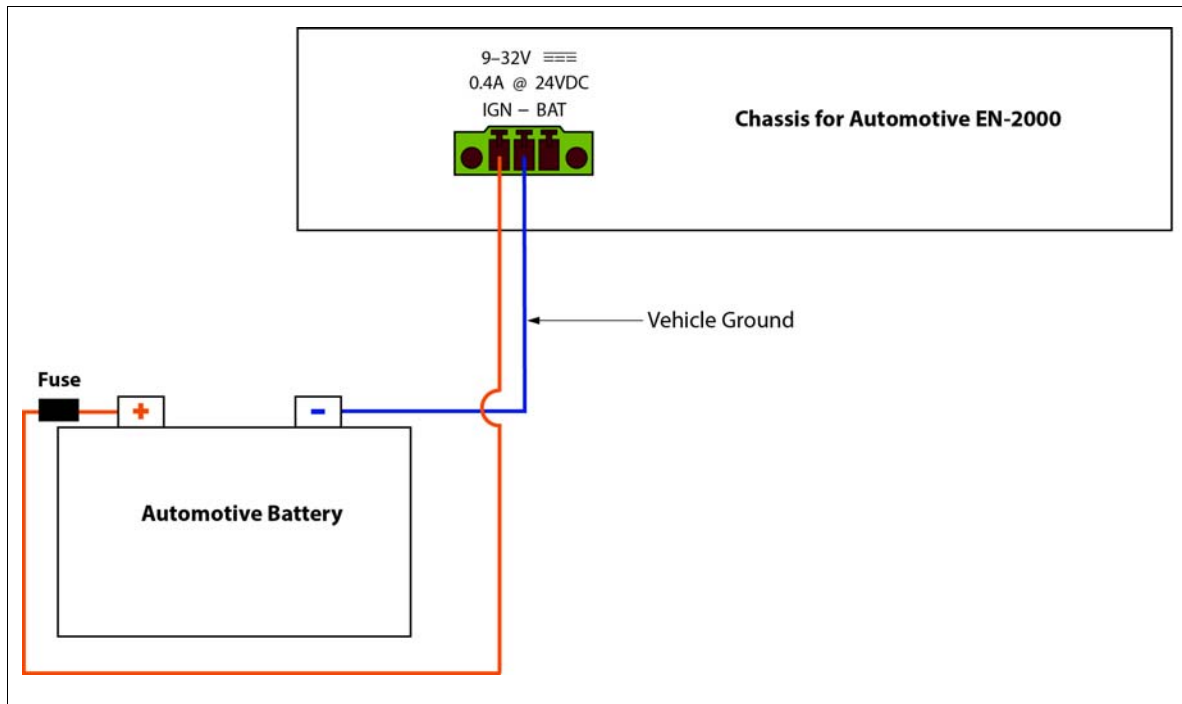

Figure C-6. Automotive EN-2000 Power Connection with Power Always On



C.3.2 Using a Temporary Connection to the Automotive EN-2000 for Testing and Evaluation

For quick testing and evaluation, the automotive EN-2000's DC connector can use a temporary connection to one of the automobile's 12V accessory sockets (formerly called cigarette-lighter outlets).

Contact your vendor for the adapter cable to connect the automotive EN-2000's DC connector to a 12V accessory socket. The tip of the adapter plug for the 12V accessory socket is positive (+); the wings (on the side of the plug) are negative (-). If that cable is not available, the customer will need to build the cable.

Warning: Connection to the 12V accessory socket is only for quick testing purposes. That connection quickly drains the automotive battery. If your organization chooses to use a temporary connector to a 12V accessory socket, set up that connection for immediate shut-off when the vehicle is not in use.

Encore Networks, Inc., does not endorse installation of an automotive EN-2000 via connection to a 12V accessory socket.